

JetSeed™ Granule Spreading System

Quick Start Guide

Version 1.1 [En](#)

To Users

Dear user, thank you for choosing XAG products.

For safety reasons and the best experience possible, XAG recommends that you read through the User Manual and Disclaimer in this document before attempting to use the JetSeed™ Granule Spreading System.

Contact Us

If you have any questions about this document, please contact our Technical Support via email: info@xa.com

List of Items

Before unpacking and using the product, please carefully check if it contains all the items listed below. Please contact XAG™ or your dealer if there are any missing items.

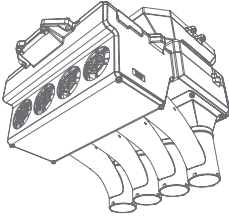

Spreader × 1

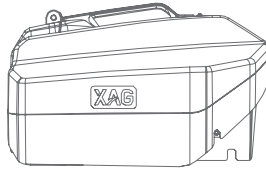

Granule Container × 1



Screw Kit × 1

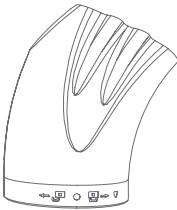

Large-angle Air Diffuser
× 2

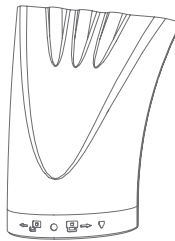

Small-angle Air Diffuser
× 2

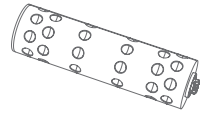

Small Rolling Feeder
× 1

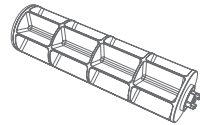

Large Rolling Feeder
× 1

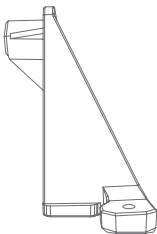

Granule Container Holder
× 2

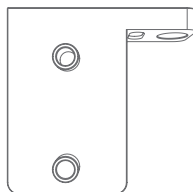

Spreader Holder
(one on each side)
× 2

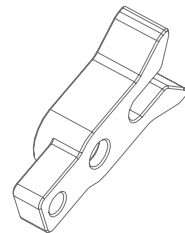

Cover Buckle
× 2

System Assembly

Pre-Assembly Preparations

Before assembling the spreading system, please remove the spraying system and some parts first.

1. Disassemble the Head Cover

Lift the head cover from the front, and push the head cover backwards.

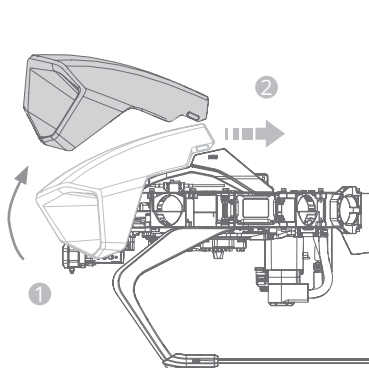

2. Disassemble the Antenna Frame

Remove six antenna frame fixing screws, and disassemble the antenna frame from the airframe.

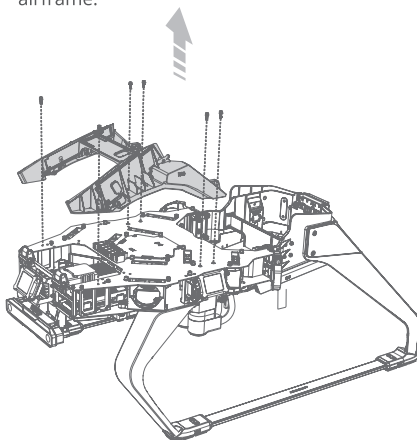

3. Remove the Container Buckle/Head Cover Buckle

- ① Open the buckles;
- ② Remove the container buckles in the direction of two arrows;
- ③ Dismantle the head cover buckles.

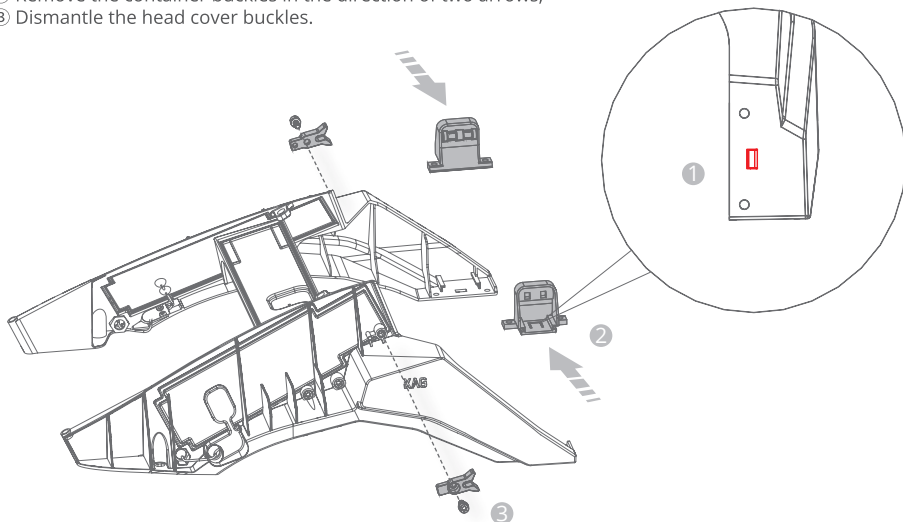

Warning To turn over the airframe, make sure its head is facing up, otherwise foreign matters may fall into the fans of the spreading system. In such cases, the damage caused is not covered by the warranty.

4. Remove the Water Pump Unit

Drain the liquid in the tubes, unplug the 4 tubes, and place them back into the central hatch. Unscrew the fixing screws of the tube adapter and the water pump unit to remove the water pump unit and the tube adapter.

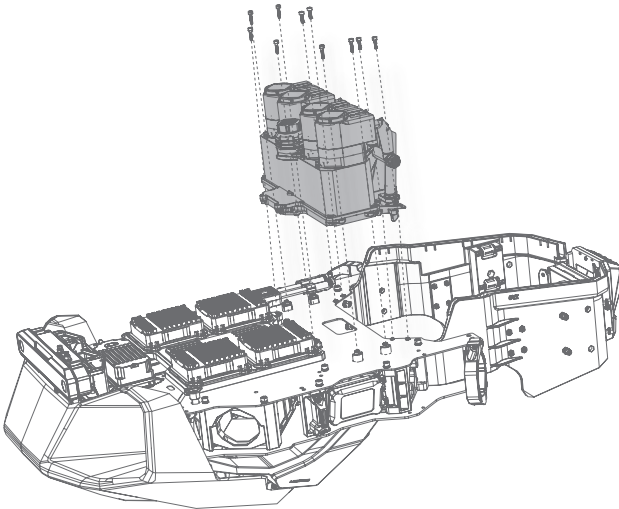

5. Remove the Carbon Frame Beam

Remove the fixing screws of the carbon frame beam to disassemble the carbon frame beam.

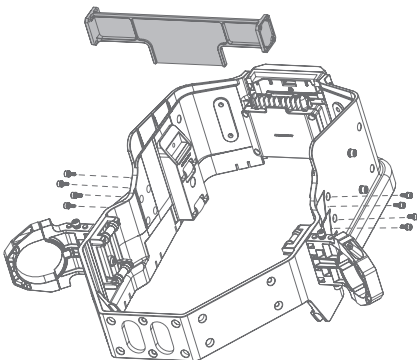

6. Remove the Container Guide Rail

Remove the fixing screws of the container guide rails to disassemble the container guide rails.

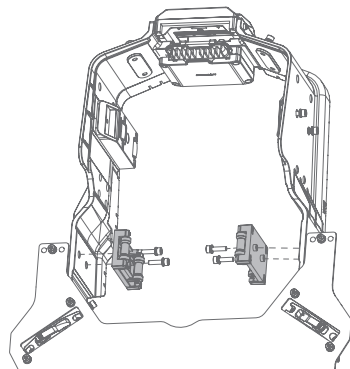

System Installation

1. Install the Head Cover Buckle

Install the head cover buckles indicated in the List of Items to the antenna frame.

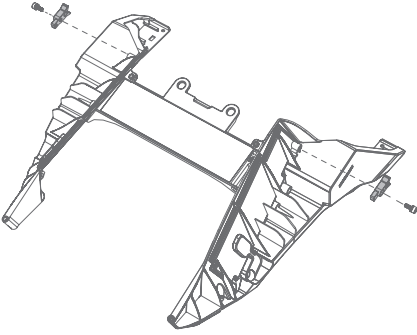

2. Assemble the 4G Antenna Frame and Granule Container Holder

Install the granule container holder into the 4G antenna frame in the direction of the arrows, and then put the 4G antenna frame back in its original place (6 pieces of M3*10 screws).

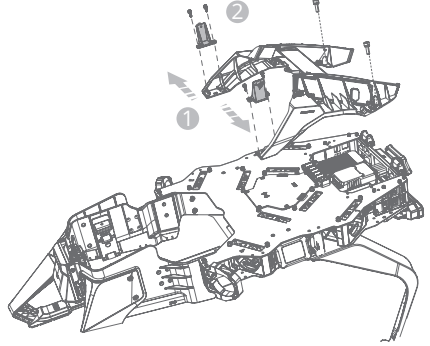

3. Install the Spreader Holder

Install the spreader holders* to the positions shown in the figure below (4 pieces of M4*16 screws).

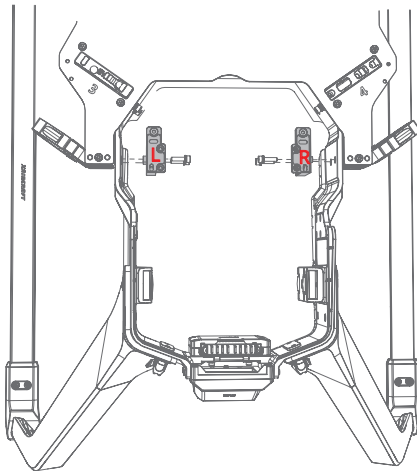

4. Assemble the Carbon Frame Beam

Install the carbon frame beam in the direction of the arrow.

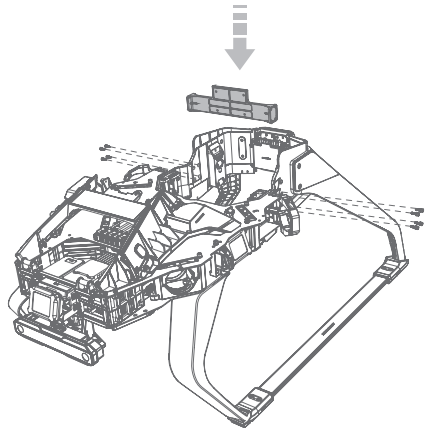

*Spreader holders are divided into L and R.

5. Install the Spreader

Install the spreader to the position shown in the figure below, tighten the 4 screws on top (M3*8) first and then the 2 at bottom (M3*20).

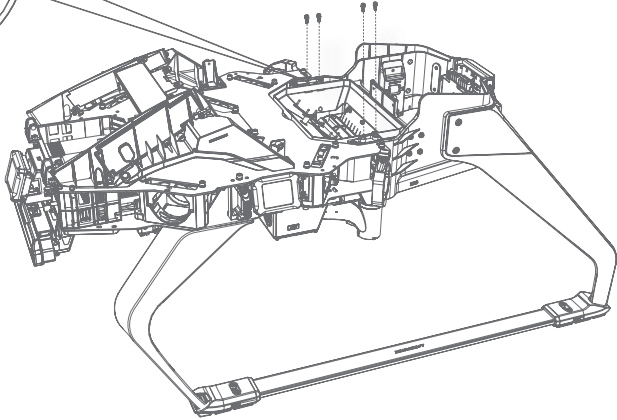
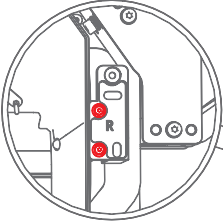

①

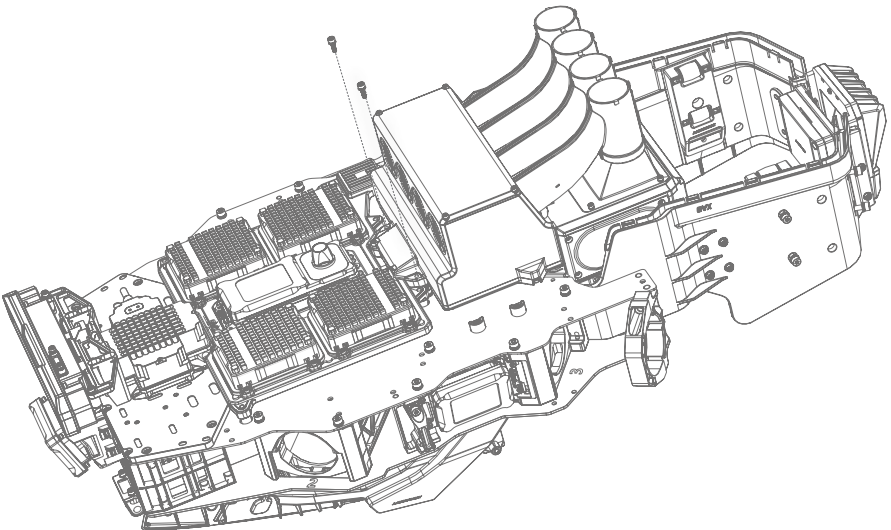

②

6. Assemble the Granule Container

Install the granule container to the position shown in the figure below (2 pieces of M3*8 screws at bottom and 2 pieces of M3*10 screws on two sides).

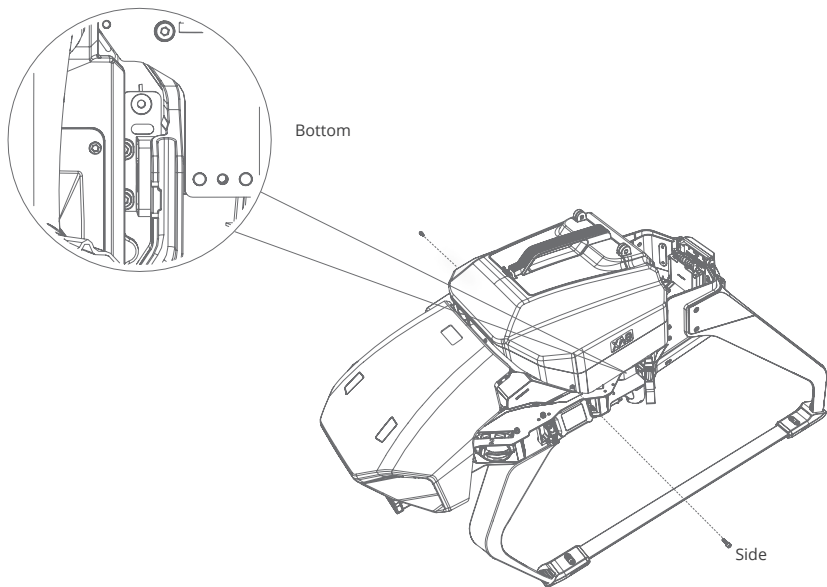

7. Install the Air Diffuser

Install the air diffusers on the T-pipe: Align the triangle mark on the air diffuser with the dot on the T-pipe, and then rotate in the lock in a clockwise direction until the dot on the air diffuser aligns with the dot of the T-pipe.

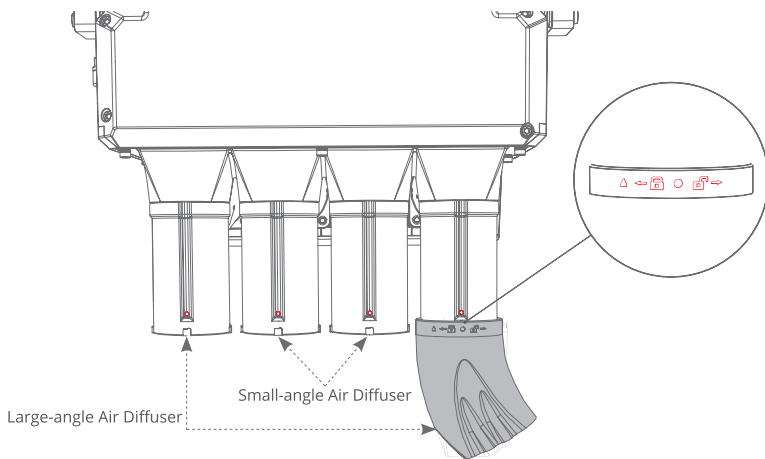

Replacing Rolling Feeder

1. Remove the old rolling feeder

Unscrew the fixing screws of the rolling feeder cover, remove the rolling feeder cover and the V-shaped stopper, and hold and pull out the rolling feeder from left.

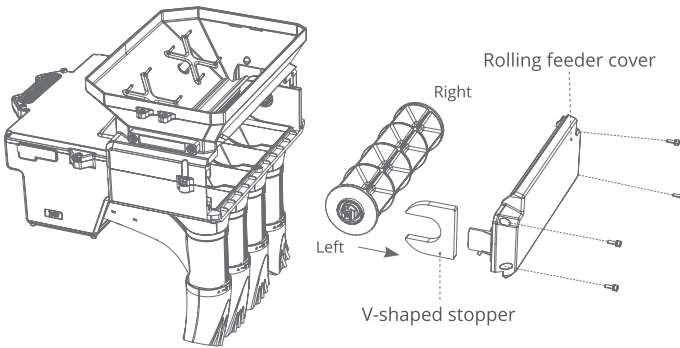

2. Install the new rolling feeder

a. Obliquely insert the convex shaft of the rolling feeder into the shaft hole. Press the left side of the rolling feeder, and clip it into the spreader.

b. Rotate the rolling feeder to check whether it is installed in place (in place: the rolling feeder is stuck and cannot be rotated. Not in place: the rolling feeder can be rotated, then clip it in place by rotating).

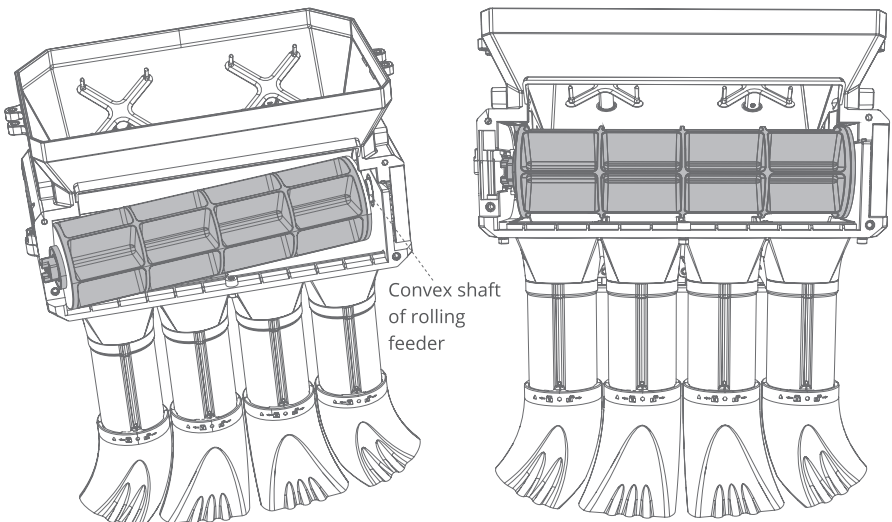

c. Install the V-shaped stopper back to its original position.

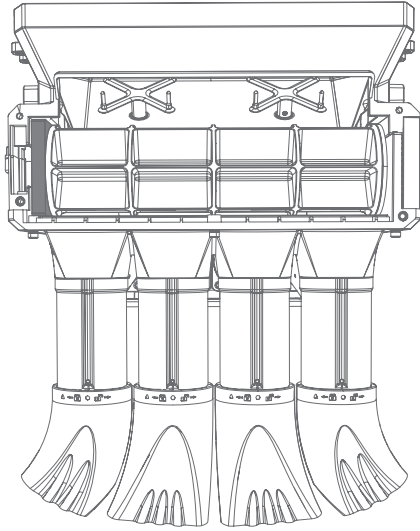

d. Install the rolling feeder cover back to its original position.

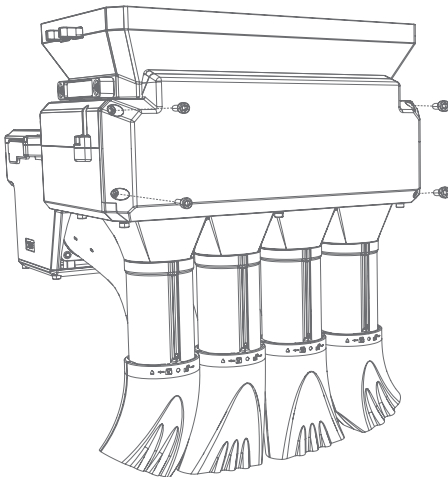

Use Instructions



JetSeed™ Granule Spreading System is compatible with the 2019 P30 Plant Protection UAS.

1. Firmware Upgrade

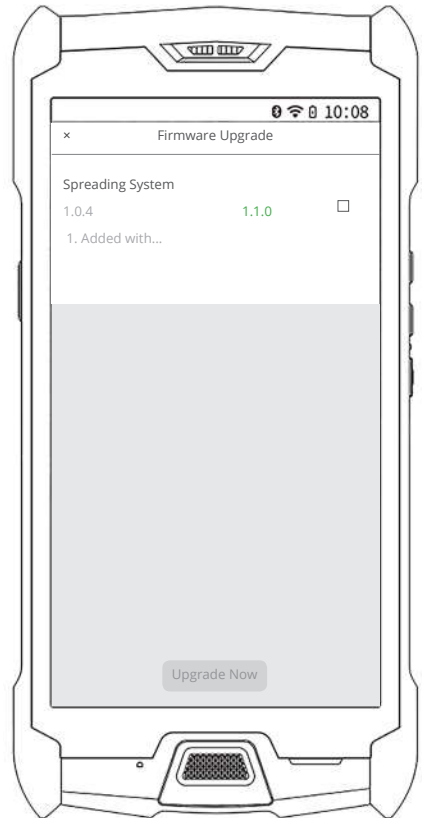
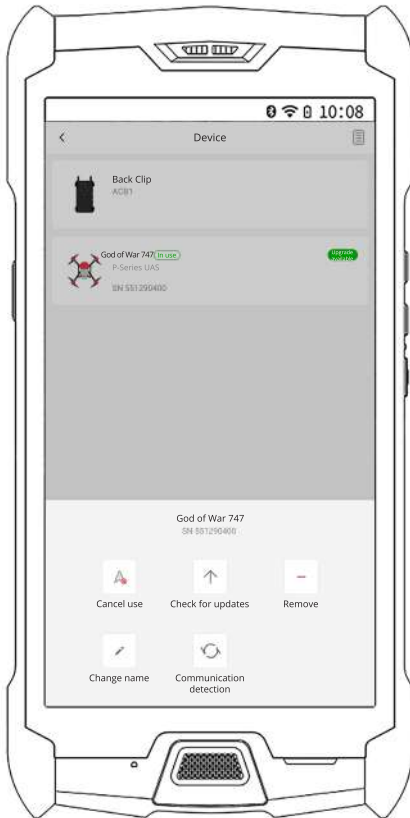
Click on the portrait in the upper left corner of the Xplanet app -- Select "Device" (P-Series UAS) -- Click to "Check For Updates" and upgrade the firmware of the "Spreading System" to the latest version.



2. Calibration

Click on the device icon in the Xplanet app  and select the "Spreading System" icon  to enter the calibration page. Before calibration, please prepare a bag and an electronic spring scale.

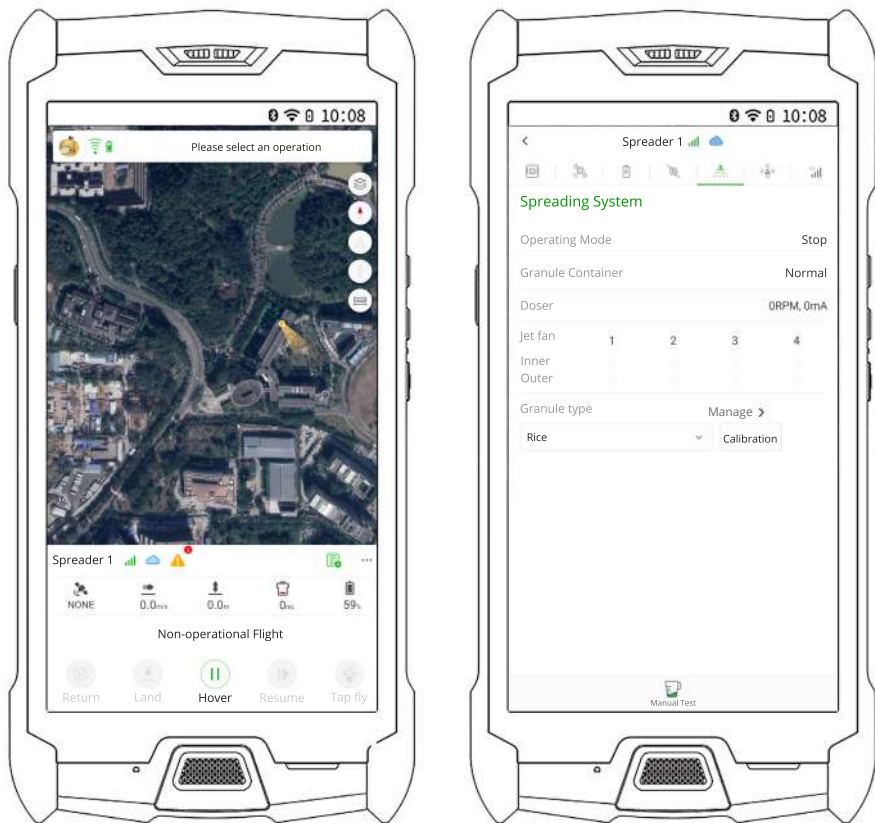

- Note**
1. Keep solid granules dry before spreading.
 2. Recalibration is needed after the replacement of the rolling feeder or a spreading operation.
 3. Since the air diffuser is close to the foot stand of the P30 Plant Protection UAS, to avoid bumps, please choose a flat ground for take-off and landing.
 4. The three types of rolling feeders are designed for different granule sizes, see below for details: Small Rolling Feeder: 1-3mm; Medium Rolling Feeder: 4-6mm; Large Rolling Feeder: 7-10mm. Choose a rolling feeder based on the dosage/ha. requirements.

How to calibrate:

Step 1: Place the bag on the electronic scale and return to zero.

Step 2: Fill the container with granules, raise the drone, and place the bag around the outlet of the air diffusers.

Step 3: Click "Manage" on the Spreading System page, and add or delete "Granule type" as required.

Step 4: Click "Calibrate", the Spreading System will automatically discharge the granules. After calibration is completed, weigh the bag and its content with the electronic scale. Enter the actual weight in grams into the app and click "Save".

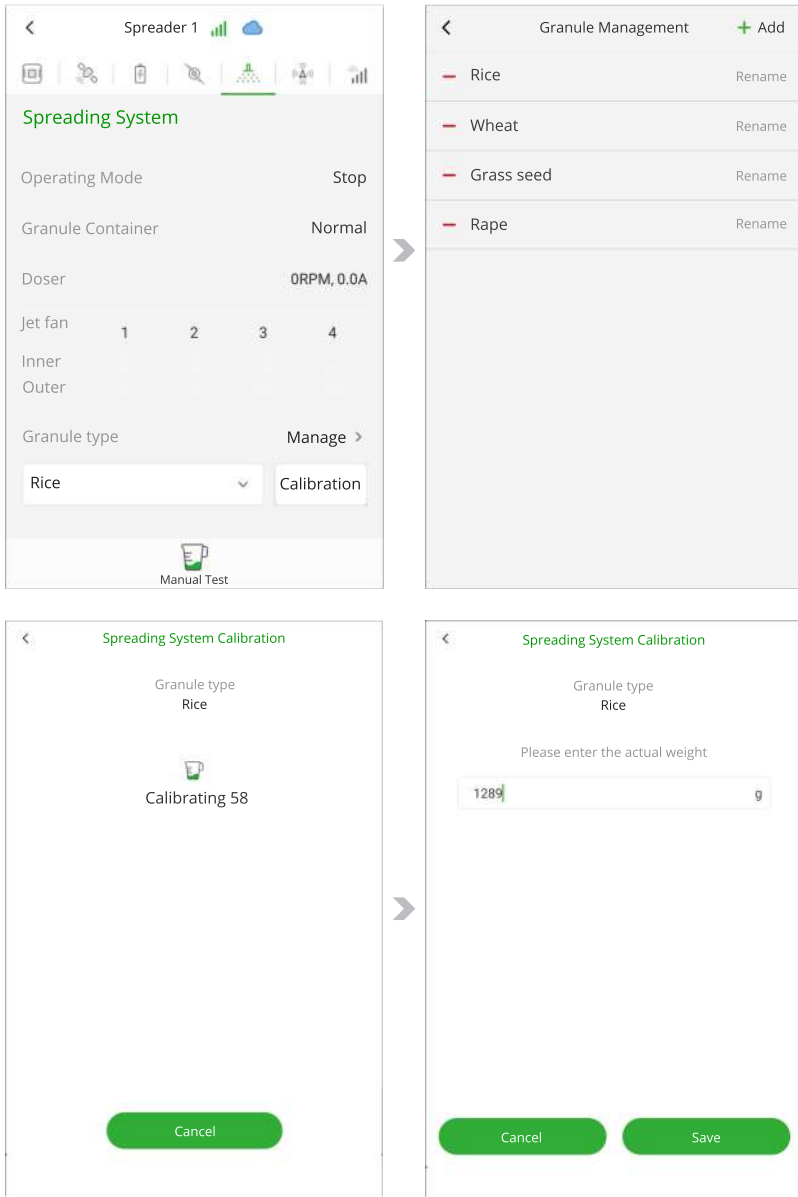

3. Manual Test

"Doser" and "Airflow volume" are displayed at the bottom of the Spreading System page. By controlling the rotation speed of the rolling feeder and fans, the user can manually test whether the Spreading System is working properly.

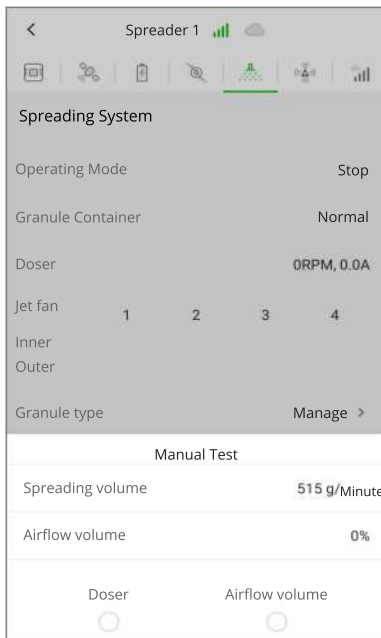

4. Spreading Parameters Settings

On the Operation Parameters page, click "Dosage" to enter the Spreading Parameters page, where the user can set "Granule type", "Dosage", and "Air speed". The estimated total dosage of the current flight operation is displayed in the upper right corner.

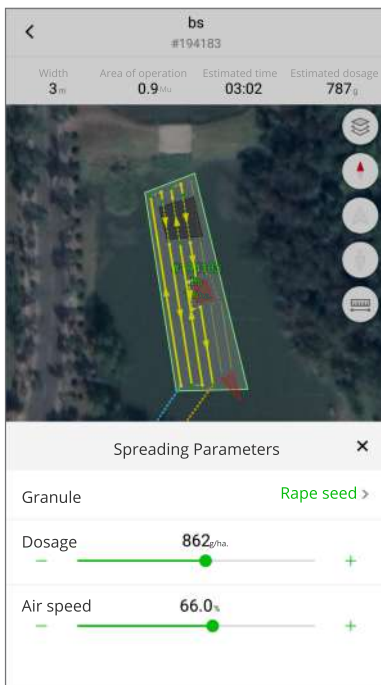

Technical Specifications

JetSeed™ Granule Spreading System

Weight: 2.5 kg
 Waterproof grade: IP55
 Operating temperature: -20° - 60° C
 Storage temperature: -10° - 40° C
 Width: Valid width: 2.5 ~ 4.5 m
 (Depending on the operating height, granule weight, air speed of feeding, and dosage/mu)
 Rotation speed of rolling feeder: 20-80r/min
 Air speed of feeding: 0-18m/s
 Applicable granule size: 1-10 mm (solid granule)

• Download XPlanet App



Scan to visit XAG Academy
 Download XPlanet App

Disclaimer

1. Please read this document carefully before using this product. This Disclaimer has an important impact on the safe use of the product and your legitimate rights and interests. The use of the product shall be deemed as you have known, understood, acknowledged, and accepted all terms and contents of this document.
2. This product is not a toy, and is not suitable for people under the age of 18. Please keep this product away from the reach of children, and be very careful when operating in the presence of children.
3. Please install and use this product as guided by the "Product Manual/Operation Manual". Do not modify or disassemble the product without authorization. All losses caused by the user's unauthorized modification or disassembly of this product shall be borne by the user, while XAG does not assume any corresponding legal responsibility.
4. To the maximum extent permitted by law, XAG shall not be liable for any losses caused by users' failure to use the product in accordance with this document and the "Product Manual/Operation Manual".
5. To the maximum extent permitted by law, XAG's liability or amount under any circumstances to you for all damages, losses, and litigation arising therefrom will not exceed the amount paid to XAG by you for the purchase of the product.
6. In any case, the purchaser or user shall comply with relevant laws and regulations of the country and region where the product is used. XAG does not assume any liability arising from violation of relevant laws and regulations by the purchaser or user.
7. As laws in some countries may prohibit exemptions from liability clauses, your rights in different countries may vary. This does not mean that the contents of this Disclaimer are necessarily invalid.
8. To the extent permitted by law, XAG has the final right to interpret and modify the above terms. XAG has the right to update, modify, or terminate these terms through its official website, the "Product Manual/Operation Manual", online APP and other means without prior notice.

Warning

Users are required to read the complete "Product Manual" and be familiar with the product operations before using the product. Otherwise, it may cause serious injury to yourself or others, or cause product damage and property loss. Strong safety awareness is required to operate this product. Do not use the parts that are not provided or suggested by XAG. Please strictly follow the instructions of XAG to install and use the product.

Visit our website (www.xa.com/en) for more information



info@xa.com



@XAGofficial



@XAG_official



This Manual is subject to upgrade without prior notice.

©XAG Co., Ltd. All Rights Reserved.

All information of this User Manual (including but not limited to any text description, illustrations, photos, methods and processes, etc.) belongs to XAG Co., Ltd. and is protected by copyright law. Without written authorization, no individual or institution is allowed to reproduce, extract, translate, distribute, or otherwise reproduce or quote any content hereof.